

Buyer's Guide Top Running & Under Running Single Girder  
Electric Traveling Cranes Utilizing Under Running Trolley Hoist

Prepared by  
The Crane Manufacturers Association of America, Inc

74

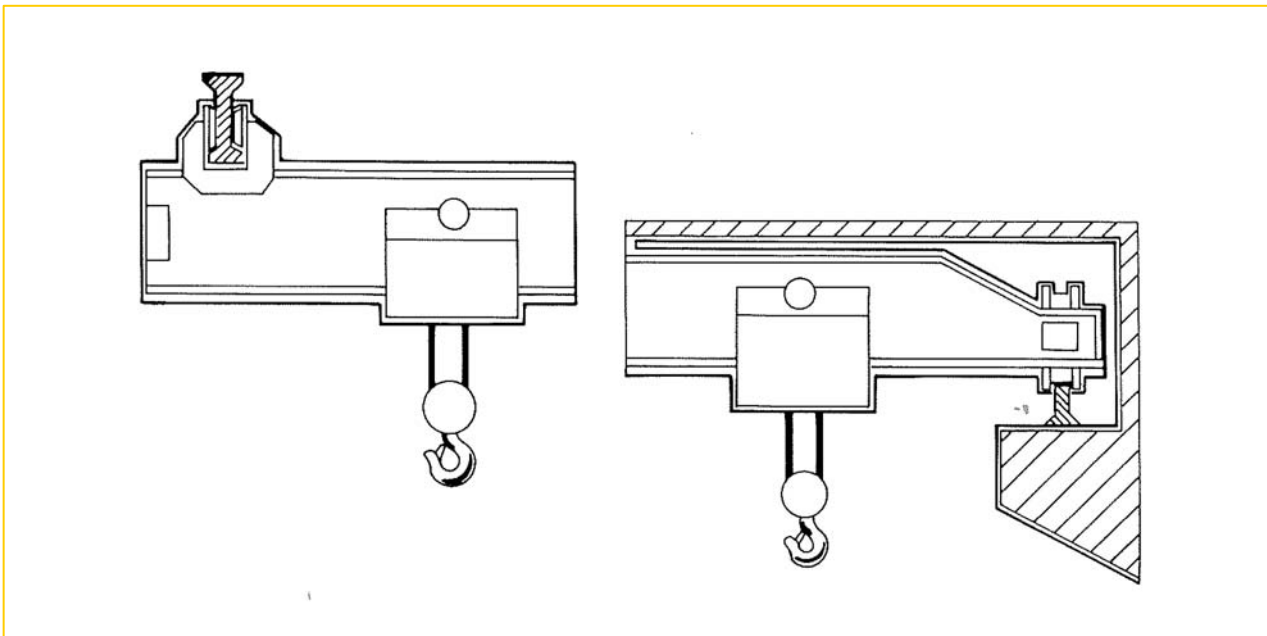

Released December 2008

## **Disclaimer for CMAA BUYERS' GUIDE**

This Guide, which was developed by the Crane Manufacturers Association of America an independent trade association affiliated with the Material Handling Industry of America (“MHIA”), a division of the Material Handling Industry (“MHI”), provides guidance about the proper selection of a material handling system and covers issues such as the service for which it will be used, the frequency of its use, matching its speed with manufacturing needs, budget and more. It was developed with the sole intent of offering information to parties engaged in selecting and purchasing such a material handling system. This Guide is advisory only and should be regarded as a simple tool that the buyer may or may not choose to follow, adopt, modify, or reject. The following information does not constitute a comprehensive safety program, cannot guard the buyer from pitfalls in selecting and purchasing such a system, and should not be relied upon as such. Such a program should be developed, and an independent adviser should be consulted to do so.

**VOLUNTARY.** The acceptance or use of this Guide is completely voluntary. Its existence does not in any respect preclude anyone, whether it has approved the Guide or not, from following procedures and assuming responsibilities not conforming to this Guide.

**DISCLAIMER OF LIABILITY.** CMAA, the Material Handling Industry, MHIA, and their members assume no responsibility and disclaim all liability of any kind, however arising, as a result of acceptance or use or alleged use of this Guide. User specifically understands and agrees that CMAA, the Material Handling Industry, MHIA, and their members, their officers, agents, and employees shall not be liable under any legal theory of any kind for any action or failure to act with respect to the proper selection of a material handling system as well as matters such as the service for which it will be used, the frequency of its use, matching its speed with manufacturing needs, budget or any other activity covered by This Guide. Any use of this information must be determined by the user to be in accordance with applicable federal, state, and local laws and regulations.

**DISCLAIMER OF WARRANTY.** CMAA, the Material Handling Industry, MHIA, and their members make no warranties of any kind, express, implied, or statutory, in connection with the information in this Guide and specifically disclaim all implied warranties of merchantability or of fitness for particular purpose.

**INDEMNIFICATION.** By referring to or otherwise employing This Guide, the user agrees to defend, protect, indemnify, and hold CMAA, the Material Handling Industry, MHIA, their members, their officers, agents, and employees harmless from and against all claims, losses, expenses, damages, and liabilities, direct, incidental, or consequential, arising from acceptance or use or alleged use of this Guide, including loss of profits and reasonable attorneys' fees which may arise out of the acceptance or use or alleged use of this Guide. The intent of this provision and of the user is to absolve and protect CMAA, the Material Handling Industry, MHIA, their members, their officers, agents, and employees from any and all loss relating in any way to this Guide, including those resulting from the user's own negligence.

# CMAA Buyer's Guide

## INTRODUCTION

The Crane Manufacturers Association of America, known as CMAA, is an organization of over thirty leading American manufacturers of electric overhead traveling cranes and components.

CMAA has published standardized crane specifications for almost sixty years. Two publications in particular, *CMAA 70 – Specifications for Top Running Bridge & Gantry Type Multiple Girder Electric Overhead Traveling Cranes* and *CMAA 74 – Specifications for Top Running & Under Running Single Girder Electric Traveling Cranes Utilizing Under Running Trolley Hoist*, are recognized throughout the United States as the *de facto* standards of industrial crane design.

CMAA traces its roots to the Electric Overhead Crane Institute, known as EOCI, which was founded in 1927 by leading crane manufacturers of that time to promote standardization of cranes, uniform quality and performance. EOCI published standardized specifications in 1949 and again in 1961.

*CMAA Specification 70*, first published in 1971, superseded *ECCI 61*. Since 1971, *CMAA Specification 70* has been republished several times with changes and updates managed by CMAA's Engineering Committee. *CMAA Specification 74* was first published in 1974 to provide similar design information on single girder cranes.

CMAA has organized this Buyer's Guide to promote standardization and to assist prospective buyers of electric overhead traveling cranes in selection of equipment most suitable for their applications.

Thank you for your interest in CMAA and its Members.

---

# **BUYER'S GUIDE**

## **FOR**

### **TOP RUNNING & UNDER RUNNING SINGLE GIRDER ELECTRIC TRAVELING CRANES UTILIZING UNDER RUNNING TROLLEY HOISTS SPECIFICATION #74, REV. 2004**

The proper selection of a material handling system involves determining several key items, which include:

1. The “Service” the system will be used for and
2. The “Frequency” of its use and
3. The “Speed” of the system necessary to match process parameters and
4. The Buyers Budget.

Beginning on page 7 is a set of “Crane Inquiry Data Sheets”. This is an excellent starting point to discuss your requirements with the crane manufacturer. Some items require your input, while a discussion with the crane manufacturer would be best for judgment-type questions where his knowledge would help you arrive at an optimal solution.

Page 12 outlines “Crane Service Classifications” that provides guidelines for selecting the proper crane based on the load spectrum reflecting the actual service conditions as closely as possible.

On page 13 is Figure 6.2, “Suggested Operating Speeds”, from CMAA Specification #74, which provides additional guidelines for selecting the proper travel and hoisting speeds.

Slides providing insight into the many different types of overhead material handling equipment built by our member companies is available on our website under CMAA Buyer’s Guide. These can be used as references as you select cranes and equipment to solve your material handling needs.

CMAA recommends that the Buyer review the following set of questions with its prospective crane system supplier.

Verify key components with your crane supplier:

1. Is crane designed as per Specifications for Top Running and Under Running Single Girder Electric Traveling Cranes Utilizing Under Running Trolley Hoist – CMAA Specification #74, Revised 2004?

Yes     No

2. Design stresses in accordance with CMAA Spec #74 – 1.7?

Yes     No

3. Welding – Design, Fabrication, Testing and Welder Qualifications in accordance with AWS D14.1? (see CMAA Spec #74 - 3.2)

Yes     No

4. Are static/dynamic load factors and load combinations consistent with CMAA requirements? (see CMAA Spec #74 - 3.3)

Yes     No

5. Are calculated stresses within the limitations / guidelines of Section 3.4? (see CMAA Spec #74 - 3.4)

Yes     No

6. Have the allowable stress ranges based on class of service been considered (fatigue)? (see CMAA Spec #74 - 3.4.7)

Yes     No

7. Girder design – Proportional requirements, Factors of Safety on Buckling consistent with CMAA? (see CMAA Spec #74 - 3.4.8 & 3.5.1)

Yes     No



8. Is the girder deflection as per the requirements of CMAA, which requires deflection no greater than 1/888? The deflection specified by CMAA is a good compromise between providing an economical design and a rigid structure. For applications requiring precise placement, a stiffer bridge may be desired. (see CMAA Spec #74 - 3.5.5)

Yes  No

9. Bolting – Are structural bolted joints designed in accordance with CMAA requirements? (see CMAA Spec #74 - 3.8)

Yes  No

10. CMAA Spec 74 does not comment on the design of the hoist but refers one to ASME B30.16 and the ASME HST hoist performance standards. Is the hoist supplied in accordance with ASME B30.16 and the applicable HST standard?

Yes  No

11. Load suspension parts of the hoist are designed to a min. 5:1 on ultimate strength? (see ASME B30.16)

Yes  No

12. Wire rope safety factor min. 5:1? (OSHA 1910.179(h)(2)(1) (ASME HST-4 – 3.4)

Yes  No

**NOTE:** Rope used for holding or lifting molten metal shall not exceed 12.5% of published breaking strength. (Min. safety factor = eight (8))

13. Type of wire rope or chain & size

---

---

---

14. Does hoist or hoisting machinery meet or exceed Guide for Minimum Pitch Diameter of Running Sheaves? (see ASME HST-4 3.6)

Yes  No

15. Are bearings provided consistent with the duty cycle selected?  
(see ASME HST-4M 3.8)

Yes  No

16. Are Brakes mechanical and thermal ratings consistent with HST requirements and class of service? (see ASME HST 4M – 3.9)

**NOTE:** OSHA 1910.179 (f)(2)(VI) Each independent hoisting unit of a crane handling hot metal and having power control braking means shall be equipped with at least two (2) holding brakes.

Yes  No

17. Is shafting design in accordance with CMAA requirements?  
(see CMAA Spec #74 - 4.11)

Yes  No

18. Allowable wheel loads in compliance with CMAA requirements?  
(see CMAA Spec #74 - 4.7), (see OSHA 1910.179 (e)(2)(3))

Yes  No

19. Are bumpers sized according to the CMAA requirements?  
(see CMAA Spec #74 - 4.8)

Yes  No

20. All panel and interconnecting wiring in accordance with NFPA NEC Article 610?  
(see CMAA Spec #74 - 5)

Yes  No

21. Are motors designed and constructed in accordance with NEMA MG-1?  
(see CMAA Spec #74 - 5.2)

Yes  No

22. Have the bridge and trolley requirements been calculated in accordance with CMAA guidelines for the class of service? (see CMAA Spec #74 - 5.3)

Yes  No

23. Are the controls sized for the class of service? (see CMAA Spec #74 – 5.4)

**Yes**     **No**

24. Are short circuit devices and overload devices in compliance with NFPA NEC Article 610? (see CMAA Spec #74 – 5.6)

**Yes**     **No**

25. Is a fourth runway electrification ground bar included?  
(see CMAA Spec #74 – 5.11.6)

**Yes**     **No**

26. Are Rail Sweeps provided? (see OSHA 1910.179 (e)(4))

**Yes**     **No**





**SECTION 3.1.1**  
**74-6 CRANE INQUIRY DATA SHEET**  
**FIGURE 6.1**

Customer \_\_\_\_\_

Spec No. \_\_\_\_\_

Date \_\_\_\_\_

1. Number Cranes Required \_\_\_\_\_.

2. Capacity: Hoist(s) \_\_\_\_\_ Tons

3. Required Hook Lift (Max. Including Pits or Wells Below Floor Elevation)

Hoist \_\_\_\_\_ Ft. \_\_\_\_\_ In.

4. Approximate Length of Runway \_\_\_\_\_ Ft.

5. Number of Cranes on Runway \_\_\_\_\_.

6. Service Information: (Description of Use)

Hoist:

Number of Lifts per Hour \_\_\_\_\_ Hours per Day \_\_\_\_\_

Height of Lift \_\_\_\_\_

Hook \_\_\_\_\_ Magnet \_\_\_\_\_ Other \_\_\_\_\_

Give Size & Weight of Magnet or any Attachment

Trolley:

Number Moves per Hour \_\_\_\_\_ Hours per Day \_\_\_\_\_ Speed \_\_\_\_\_ fpm

Average Movement \_\_\_\_\_ Ft.

Bridge:

Number Moves per Hour \_\_\_\_\_ Hours per Day \_\_\_\_\_ Average Movement \_\_\_\_\_



7. Furnish complete information regarding special conditions such as acid fumes, steam, high temperatures, high altitudes, excessive dust or moisture, very severe duty, special or precise load handling:

\_\_\_\_\_

\_\_\_\_\_

8. Ambient Temperature in Building: Max. \_\_\_\_\_ Min. \_\_\_\_\_

9. Material Handled \_\_\_\_\_

10. Speeds Required: Hoist \_\_\_\_\_ fpm Bridge \_\_\_\_\_ fpm Trolley \_\_\_\_\_ fpm

11. Crane to Operate: Indoors \_\_\_\_\_ Outdoors \_\_\_\_\_ Both \_\_\_\_\_

12. Current: Volts \_\_\_\_\_ Phase \_\_\_\_\_ Hertz \_\_\_\_\_ AC Volts \_\_\_\_\_ DC

13. Method of Control: Cab \_\_\_\_\_ Floor \_\_\_\_\_ Remote \_\_\_\_\_

14. Location of Control: End of Crane \_\_\_\_\_ Center \_\_\_\_\_ On Trolley \_\_\_\_\_

Other \_\_\_\_\_

15. Type of Control (Give complete information, including number of speed points)

Full Magnetic \_\_\_\_\_ Static \_\_\_\_\_ Other \_\_\_\_\_

16. Type of Control Enclosure: \_\_\_\_\_

17. Type of Motors: (Give complete information) \_\_\_\_\_

\_\_\_\_\_

18. Must wiring comply with Special Conditions or Codes \_\_\_\_\_

Describe briefly (See Items 7 & 8) \_\_\_\_\_

\_\_\_\_\_

19. Are Runway Conductors to be included:

Type: Loose Wires \_\_\_\_\_ Rigid Wires \_\_\_\_\_ Angles \_\_\_\_\_

Insulated (Mfr) \_\_\_\_\_ Other \_\_\_\_\_

20. List of Special Equipment or Accessories Desired \_\_\_\_\_

\_\_\_\_\_



21. Specify when double hook cranes, double trolley cranes or special cranes are required giving detailed information on hook spacing, etc.

---

---

22. Complete attached building clearance drawing, making special note of any obstructions which may interfere with the crane, including special clearance conditions underneath the girders or cab.

**CRANE INQUIRY DATA SHEET**

**BUILDING CLEARANCES  
FOR TOP RUNNING SINGLE GIRDER CRANES**

**BUILDING CLEARANCES  
FOR TOP RUNNING SINGLE GIRDER CRANES**

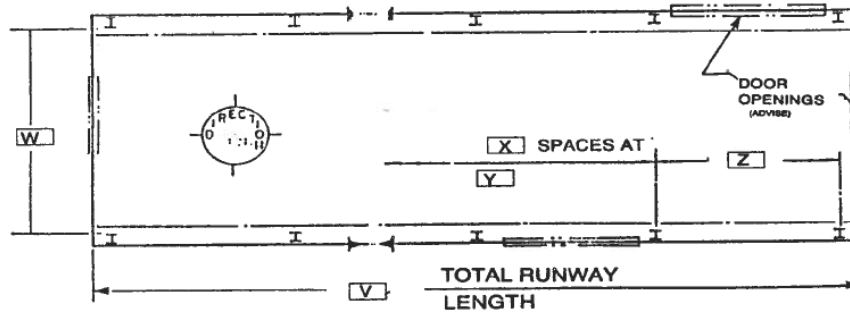
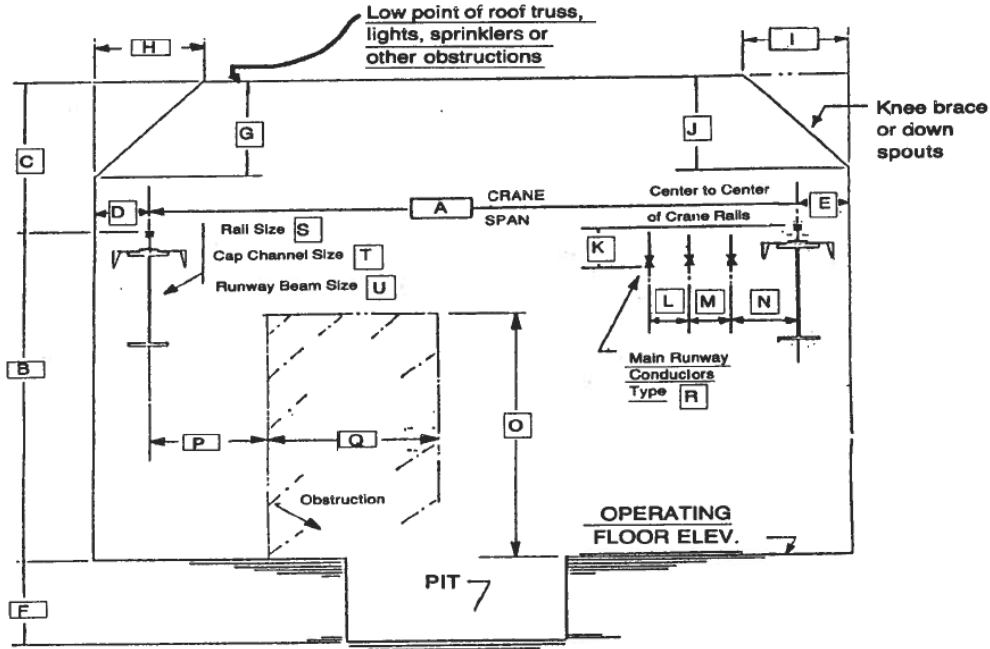

A	_____	E	_____	I	_____	Q	_____	U	_____	Y	_____
B	_____	F	_____	J	_____	R	_____	V	_____	Z	_____
C	_____	G	_____	K	_____	S	_____	W	_____		
D	_____	H	_____	L	_____	T	_____	X	_____		

A	_____	E	_____	I	_____	M	_____	Q	_____	U	_____	Y	_____
B	_____	F	_____	J	_____	N	_____	R	_____	V	_____	Z	_____
C	_____	G	_____	K	_____	O	_____	S	_____	W	_____		
D	_____	H	_____	L	_____	P	_____	T	_____	X	_____		

**CRANE INQUIRY DATA SHEET**

**BUILDING CLEARANCES  
FOR UNDER RUNNING SINGLE GIRDER CRANES**

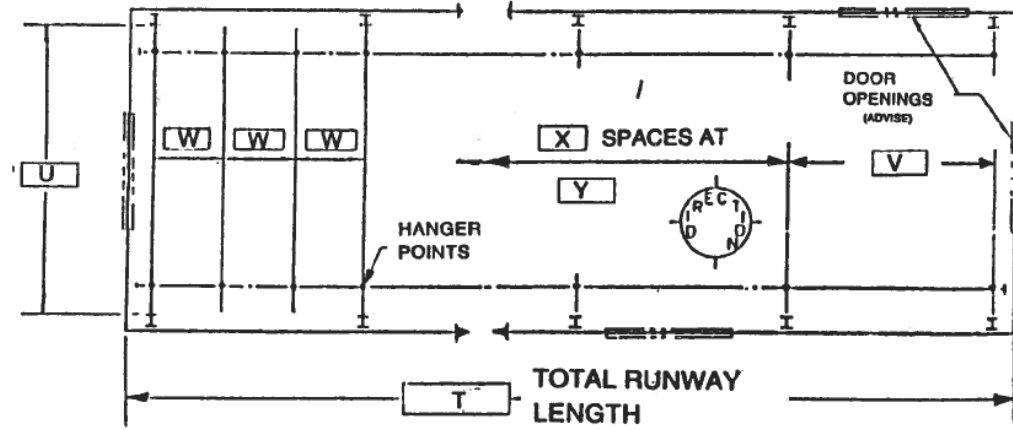
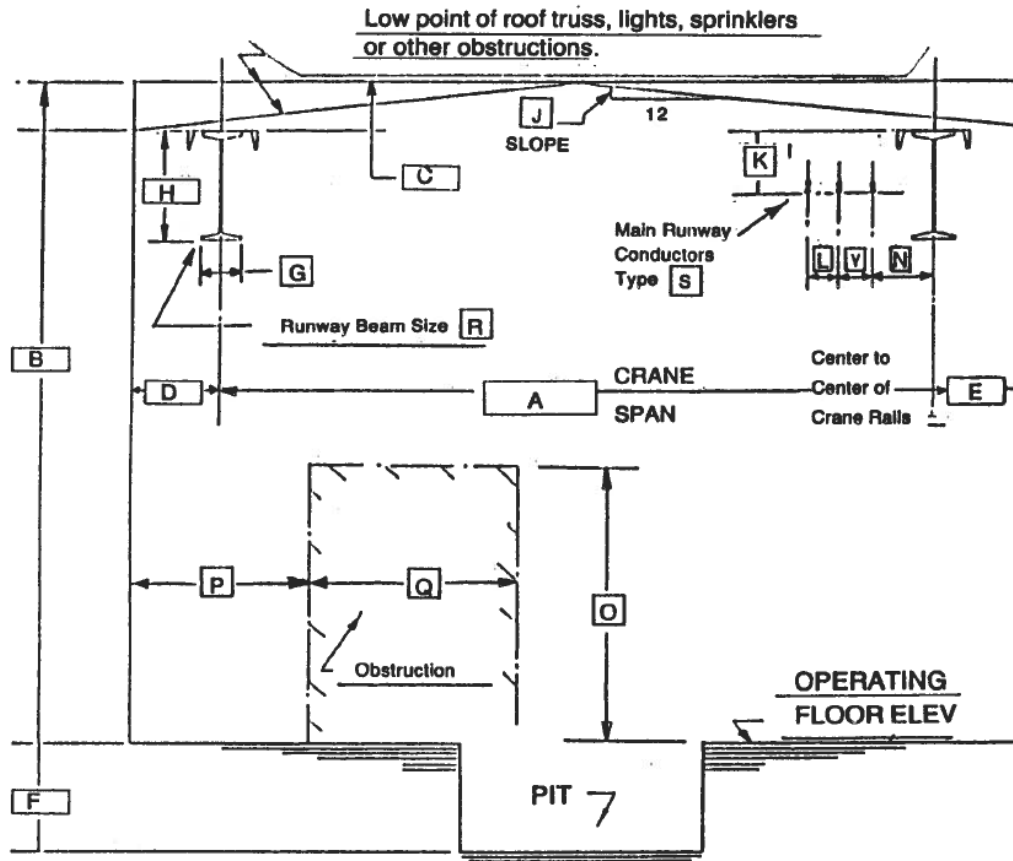

A	_____	E	_____	I	_____	N	_____	R	_____	V	_____
B	_____	F	_____	J	_____	O	_____	S	_____	W	_____
C	_____	G	_____	K	_____	P	_____	T	_____	X	_____
D	_____	H	_____	L	_____	Q	_____	U	_____	Y	_____

## Section 2.1.2

## 74-2 CRANE CLASSIFICATIONS

**CMAA Crane Service Classes**

CMAA has established crane service classes so that the most economical crane for a particular installation may be specified in accordance with *Specifications for Top Running Bridge & Gantry Type Multiple Girder Electric Overhead Traveling Cranes-No. 70* or *Specifications for Top Running and Under Running Single Girder Electric Overhead Cranes Utilizing Under Running Trolley Hoist-No. 74*. The crane service classification is based on the load spectrum reflecting the actual service conditions as closely as possible. The CMAA Crane Service Classes are as follows:

**CLASS A (STANDBY OR INFREQUENT SERVICE)**

This service class covers cranes which may be used in installations such as power houses, public utilities, turbine rooms, motor rooms and transformer stations where precise handling of equipment at slow speeds with long, idle periods between lifts are required. Capacity loads may be handled for initial installation of equipment and for infrequent maintenance.

**CLASS B (LIGHT SERVICE)**

This service covers cranes which may be used in repair shops, light assembly operations, service buildings, light warehousing, etc. where service requirements are light and the speed is slow. Loads may vary from no load to occasional full rated loads with two to five lifts per hour, averaging ten feet per lift.

**CLASS C (MODERATE SERVICE)**

This service covers cranes which may be used in machine shops or paper mill machine rooms, etc., where service requirements are moderate. In this type of service the crane will handle loads which average 50 percent of the rated capacity with 5 to 10 lifts per hour, averaging 15 feet, not over 50 percent of the lift at rated capacity.

**CLASS D (HEAVY SERVICE)**

This service covers cranes which may be used in heavy machine shops, foundries, fabricating plants, steel warehouses, container yards, lumber mills, etc., and standard duty bucket and magnet operations where heavy duty production is required. In this type of service, loads approaching 50 percent of the rated capacity will be handled constantly during the working period. High speeds are desirable for this type of service with 10 to 20 lifts per hour averaging 15 feet, not over 65 percent of the lifts at rated capacity.

This information has been presented for reference purposes only. For more information regarding load spectrum, mean effective load factors, load classes, load cycles and how these relate to the determination of crane service classes, please refer to *Specifications for Top Running Bridge & Gantry Type Multiple Girder Electric Overhead Traveling Cranes-No. 70* or *Specifications for Top Running and Under Running Single Girder Electric Overhead Cranes Utilizing Under Running Trolley Hoist-No. 74*. These documents are available for purchase online at <http://www.mhia.org/bookstore> or through the Literature Department at 704-676-1190.



**Section 3.1.2**

**FIGURE 6.2**

**SUGGESTED OPERATING SPEEDS  
FEET PER MINUTE  
FLOOR CONTROLLED CRANES**

CAPACITY IN TONS	HOIST			TROLLEY			BRIDGE		
	SLOW	MEDIUM	FAST	SLOW	MEDIUM	FAST	SLOW	MEDIUM	FAST
3	14	35	45	50	80	125	50	115	175
5	14	27	40	50	80	125	50	115	175
7.5	13	27	38	50	80	125	50	115	175
10	13	21	35	50	80	125	50	115	175
15	13	19	31	50	80	125	50	115	175
20	10	17	30	50	80	125	50	115	175
25	8	14	29	50	80	125	50	115	175
30	7	14	28	50	80	125	50	115	150



© 2008 by Crane Manufacturers Association  
of America, Inc.



CMAA is an Affiliate of  
Material Handling Industry  
8720 Red Oak Blvd., Suite 201  
Charlotte, NC 28217-3992  
Telephone: (704) 676-1190  
Fax: (704) 676-1199  
Website: [www.mhia.org/cmaa](http://www.mhia.org/cmaa)