

# Norheim Hoist Line

SINGLE & DOUBLE REEVED

YOUR CRITICAL LIFT EXPERTS



**CORPORATE HEADQUARTERS**

531 Old Swede Road • Douglassville, PA 19518  
877.877.6778 • 610.385.6061 • fax: 610.385.3191

**SERVICE, PARTS & STANDARD CRANES**

1440 Ben Franklin Highway • Douglassville, PA 19518  
877.877.6778 • 484.945.0420 • fax: 484.945.0431

**LESTER DIVISION**

10 Industrial Highway • MS10 • Q Building, 2<sup>nd</sup> Floor  
Lester, PA 19113-2002

[Sales@AmericanCrane.com](mailto:Sales@AmericanCrane.com)

[AmericanCrane.com](http://AmericanCrane.com)

Cage Code: 57335

D & B: 05-563-2376

NAICS: 333923

005

YOUR CRITICAL LIFT EXPERTS



# ACECO Modular NORHEIM HOIST



The American Crane Modular Norheim Hoist is the latest evolution in hoist design.

The modular Norheim Hoist is engineered for safety, reliability, and flexibility and is available in capacities from ½ ton to 160 tons. In addition, the hoist can be precisely adapted to meet your application requirements. The various application types – ranging from foot-mounted hoists, monorail hoists, and double rail trolleys – can be adapted to meet specific customer requirements.

As a standard, the hoist is rated for the (HMI) Hoist Manufacturers Institute Class H-4 and (CMAA) Crane Manufacturers Association of America Class D duty up to 60 tons, and CMAA Class A & B 70 Ton – 160 Ton. For Class E, F, and available easily configurable designs consult the factory.

The standard control configuration for the Norheim Hoist is the inverter drive, in conjunction with a compatible motor. A hoist inverter offers optimum utilization of the motor's output and allows very precise positioning of the load. This feature allows the lifting speed to increase for loads that weigh up to 30 percent of the rated load capacity for increased productivity. Two speed hoist and trolley control is available up to 20 HP.

Optional control contactors for two speed control are oversized to be suitable for HMI H4 and CMAA Class D service. The control enclosures are dust tight and water resistant to prevent the ingress of foreign material and non-corrosive liquids. All wiring is in accordance with NFPA NEC Article 610.

## Optional Features:

- Hazardous Electrical Applications
- Spark Proof Mechanical Components
- NEMA 4X outdoor service
- Weigh Scale Systems
- Overload Limiters
- Upper Power Circuit Limiters
- Extra-Long Lifts
- Low Profile Models
- High or Low Temperatures
- Secondary Drum Brake (Mechanical or Hydraulic)
- Special Painting Systems
- Electronic Hoist Monitoring

**OPTIONAL  
FEATURES**

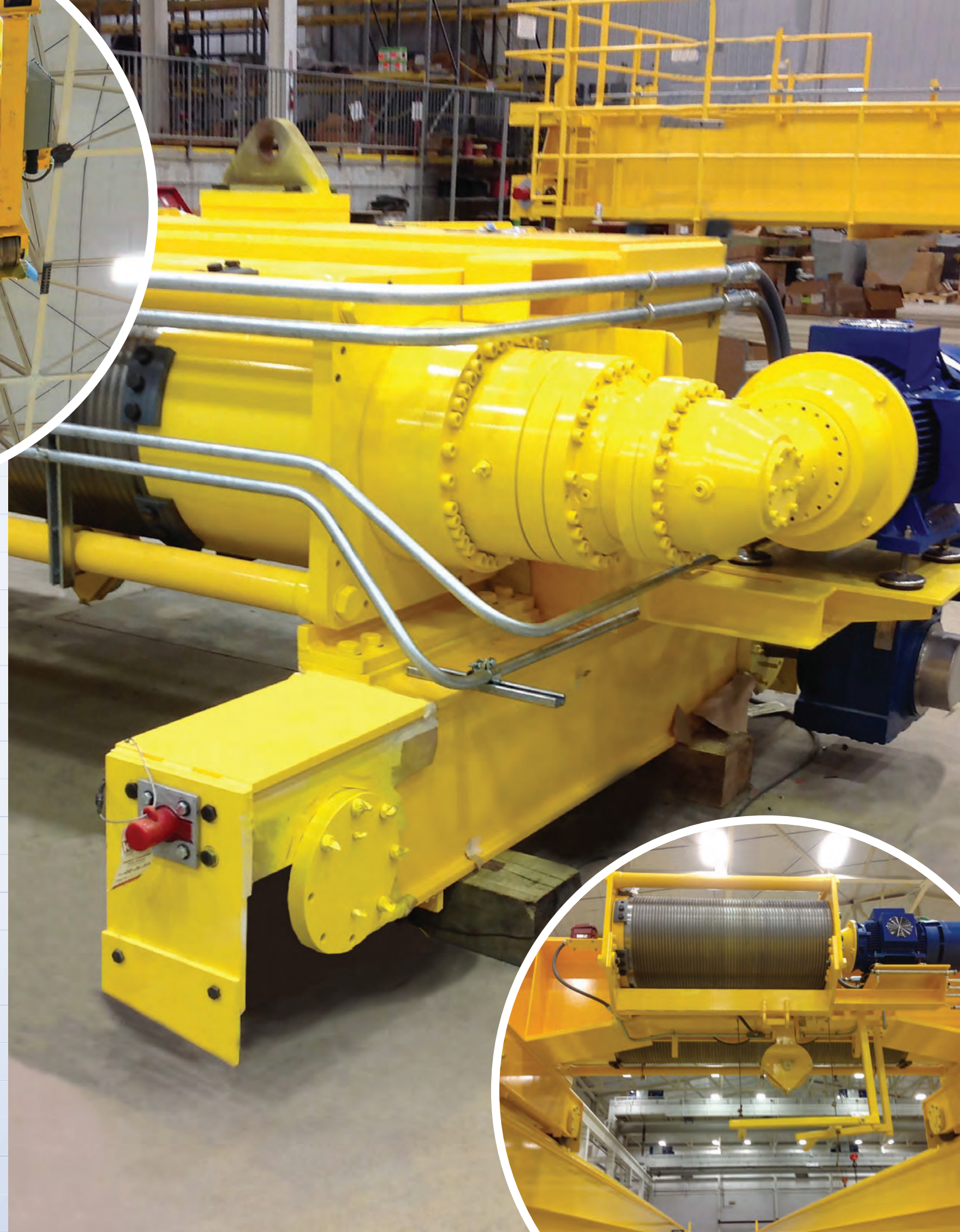

# FEATURES

## MOTOR

- Motors conforming to either NEMA MG1 or IEC 60034
- TENV, or TEFC motor with electric fan
- Enclosures constructed from cast iron, or cast aluminum
- Motor insulation Class F rated minimum (105 degrees Celsius rise above ambient)
- Normal temperature rise for a 1.0 service factor operation with Class B rise
- Efficient cooling with ribbed frames
- Time rating NEMA 60 minute duty, or S3 - 40% IEC duty
- Supplied with a pulse encoder for use with variable frequency drive
- Two speed motors available up to 20 HP

## HOIST BRAKE

- Integrally mounted, spring set, electrically released (fail safe)
- 150% rated motor torque minimum, 250% rated motor torque maximum
- Disc type, self-adjusting to compensate for wear
- Provided with a manual brake release, dead-man type
- Thermally suitable for hoisting service

## HOIST GEARBOX

- Gearing designed and manufactured to high quality AGMA 12 specifications
- Alloy steel planetary gearing for high torque density, and high efficiency
- Planetary gears mounted onto self-centering carriers to ensure the most even load distribution among planetary gears
- High overhung load capacity, using heavy duty tapered roller bearings
- Inner parts are coupled through splined connections, rather than keys
- Ductile cast iron housing with oil splash lubrication

## DRUM / REEVING

- Thick wall steel tubing machined with grooving up to 50% of the rope diameter
- Drum/sheave diameter ratios typically exceed HMI and CMAA recommendations
- Extra Flexible steel core wire rope designed with 5:1 safety factor
- Rope dead end connections using standard clamps
- Sheaves fabricated from alloy steel running on anti-friction bearings
- Hoist rope fleet angles designed to meet CMAA specifications
- Bottom block provided with forged steel hook on swivel thrust bearing



## MONORAIL TROLLEY

The Norheim hoist can be tailored to meet your exact requirements for operation on a monorail beam. Standard monorail configurations offer the following advantages:

- Low headroom design as standard using double reeving
- Trolley wheels driven on both sides of the beam for balanced traction
- Trolley spacing adjustable to fit wide range of beam sizes
- Trolley drive gears and wheels are pre-lubricated
- Safety drop lugs are a standard feature
- Capacities up to 20 tons as standard. Higher capabilities available

## TOP RUNNING TROLLEY

The Norheim hoist can be tailored to meet your exact requirements for operation as a top running trolley. Standard top running trolley configurations offer the following advantages:

- Trolley frames are construction of welded fabricated sections
- Trolley design and construction assures equal wheel loading
- Wheels are supported by heavy duty, anti-friction bearings to exceed CMAA life requirements
- Modular gear motors with hardened alloy steel helical gearing
- Standard trolleys designed to meet or exceed HMI H4 duty (CMAA Class D)
- Single Reeved Capacities up to 90 tons
- Double Reeved Capacities up to 160 tons

## SUMMARY

The American Crane Norheim Modular hoist is the result of years of engineering resulting in a design that utilizes readily available, commercial components. The design provides versatility in a wide variety of applications resulting in a product with unmatched reliability, ruggedness and cost effective operation. When you buy an American Crane Norheim hoist, you can buy it with confidence that it will be on the job for many years to come.

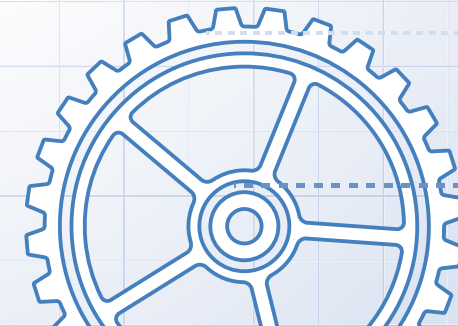

# PRODUCTS

**TYPE 16**  
**Top Running Trolley; Low Profile; Double Reeved**  
CAPACITY: 15 – 50 Ton

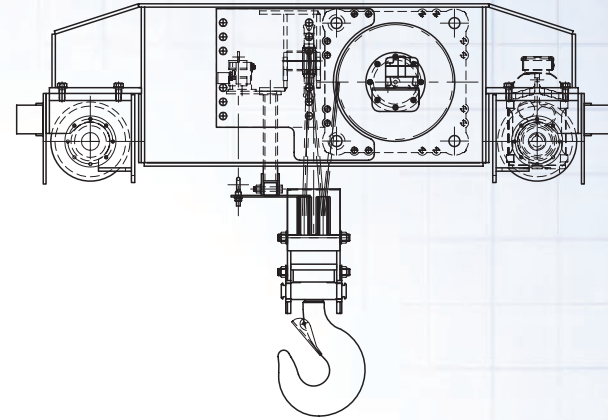
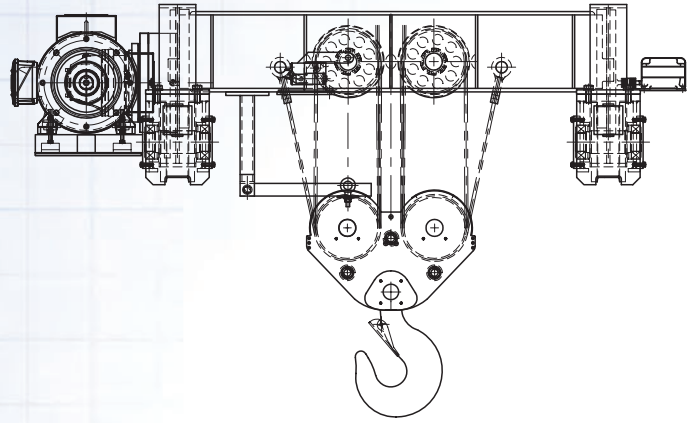

**TYPE 18**  
**Top Running Trolley; Standard Profile; Double Reeved**  
CAPACITY: 15 – 160 Ton

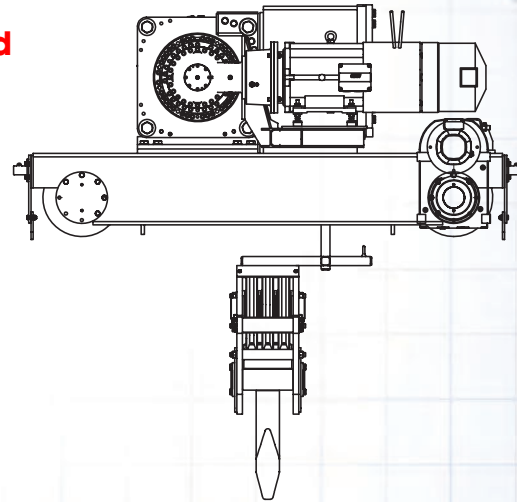
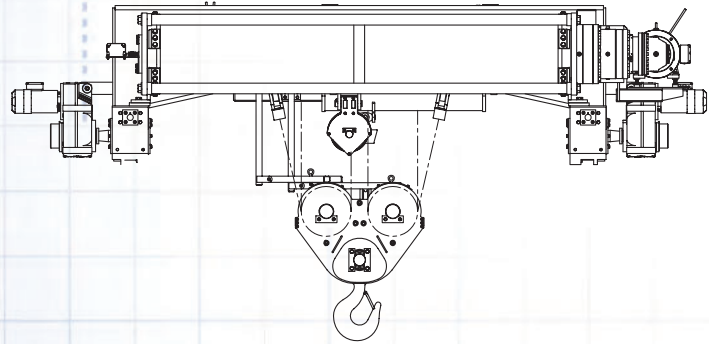

**TYPE 19**  
**Top Running Trolley; 2 Part Double Reeving; Double Reeved**  
CAPACITY: 5 – 15 Ton

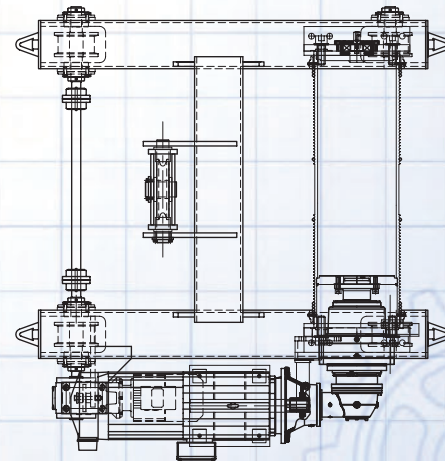
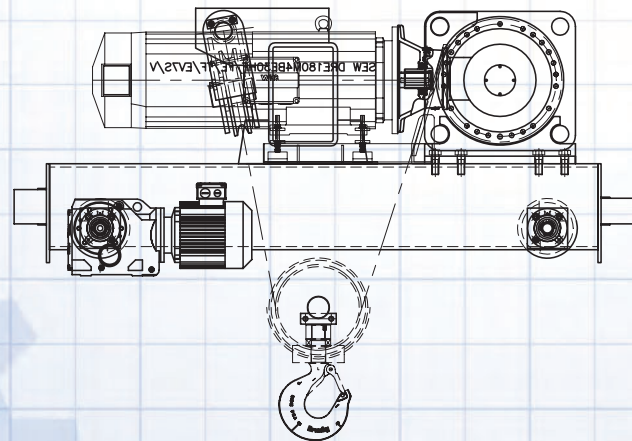

**TYPE 32**  
**Monorail Standard Trolley; Double Reeved**  
CAPACITY: 1/2 – 15 Ton

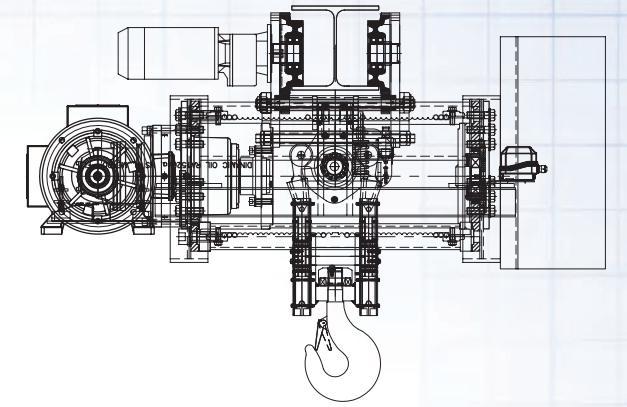
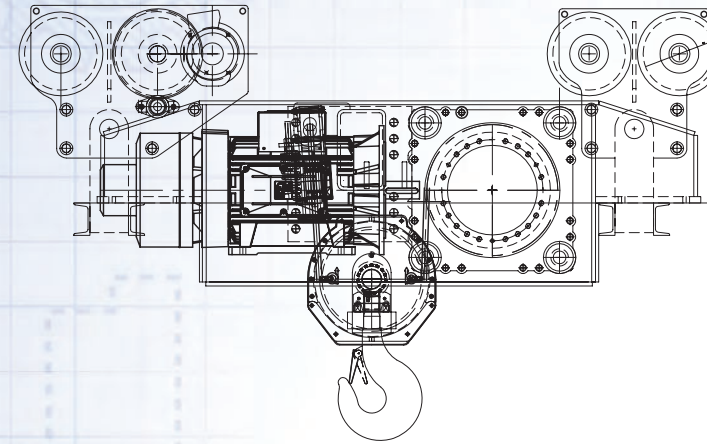

**TYPE 23**  
**Monorail Standard Trolley; Single Reeved**  
CAPACITY: 3 – 20 Ton

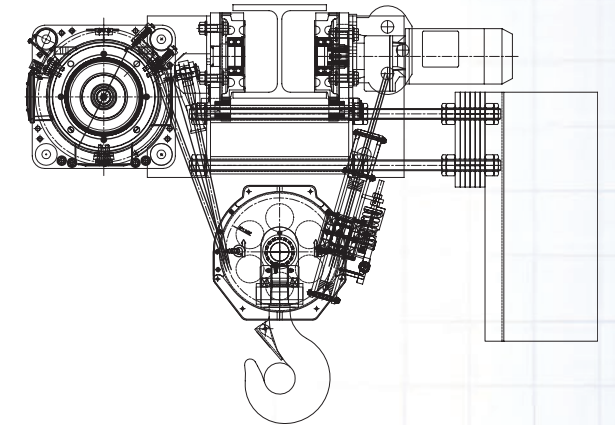
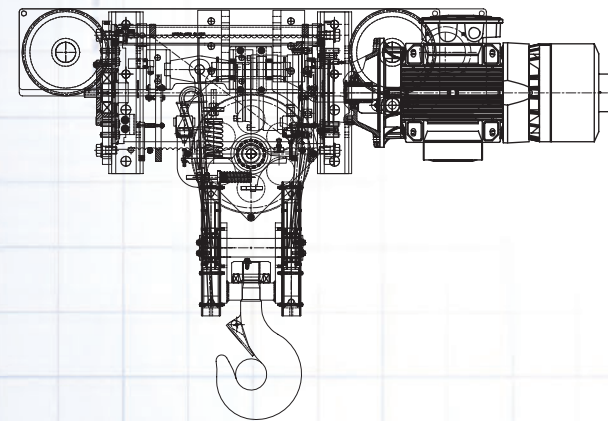

**TYPE 26**  
**Top Running Trolley; Single Reeved**  
CAPACITY: 3 – 90 Ton

